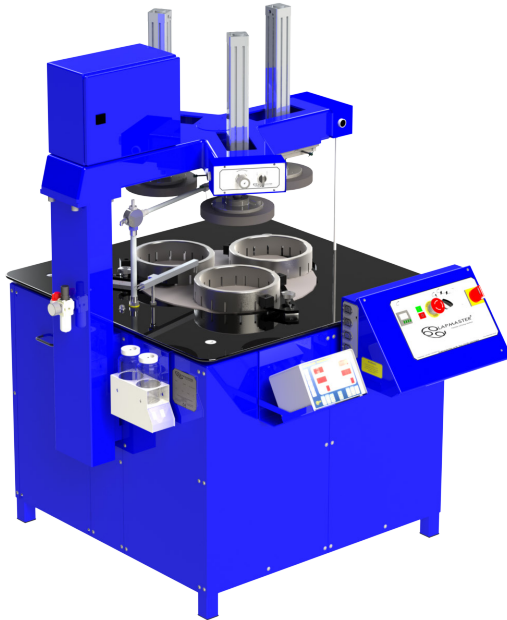

PRECISION PNEUMATIC LIFT DIAMOND FLAT LAPPING/POLISHING MACHINE

The pneumatic lift version of the Lapmaster Wolters Model 24 is based on the open face machine.

Pressure weights are attached through self aligning bearings to the rods of the pneumatic cylinders. The cylinders are mounted on a framework located over the lap plate on two upright columns.

The primary function of the pneumatic arrangement is to permit loading and unloading to be carried out without the need to lift pressure weights manually. However, they can be used to supply additional loading to the components within the conditioning ring should this be required.

The machine is intended for use with an electronic dispensing system for use with water and diamond compounds etc. A standard abrasive system is also fitted for periodic reconditioning of the lap plate.

Operator safety is a primary concern in the design. Movement of each pressure weight up or down is controlled by a two hand anti tie down control box. This arrangement requires the use of both hands on two separate buttons to function and ensures the operator cannot injure their hands or arms when lowering the weights.

A further safety feature is that the pressure weights are locked in any position, so that in the event the air or electrical supplies fail, the weights will not fall.

Flatness of the machines lap plate, and consequently of the work, is controlled by adjusting the position of the conditioning rings relative to the lap plate track.

The lapping plate drive system utilises a separate motor and worm & wheel mechanical reduction gearbox with single belt drive.

STANDARD FEATURES

- Heavy duty floor standing base with integrally mounted drive motor, reduction gearbox.
- Range of loads for pressure weights 15Kg (33lb) to 85Kg (187lb.) at 4.2Kg/cm² (60 psi.)
- Heavy duty work table, vertically adjustable.
- Three conditioning rings, with adjustable, sealed roller bearing yoke assemblies to maintain lap flatness.
- Multi purpose dispensing system, complete with electronic dispensing unit, spray arm and electronic stirrer.
- Free standing abrasive system complete with pump and multiple point compound distribution.
- High torque drive unit consisting of 1.5kW motor and reduction gearbox. Lap plate speed 70 rpm.
- Operator controls at 110V, complies with EN 60 204.
- CE compliant.
- Operator panel with start / stop controls, and multiple range digital process timer.
- Waste tank.

STANDARD TOOLING

- Composite Lap Plate. 610mm O.D. x 114mm I.D.
- Three high density cast iron serrated conditioning rings. 286mm O.D. x 248mm I.D.
- Three blank workholder discs.
- Three felt pads.
- Operation and maintenance manual.

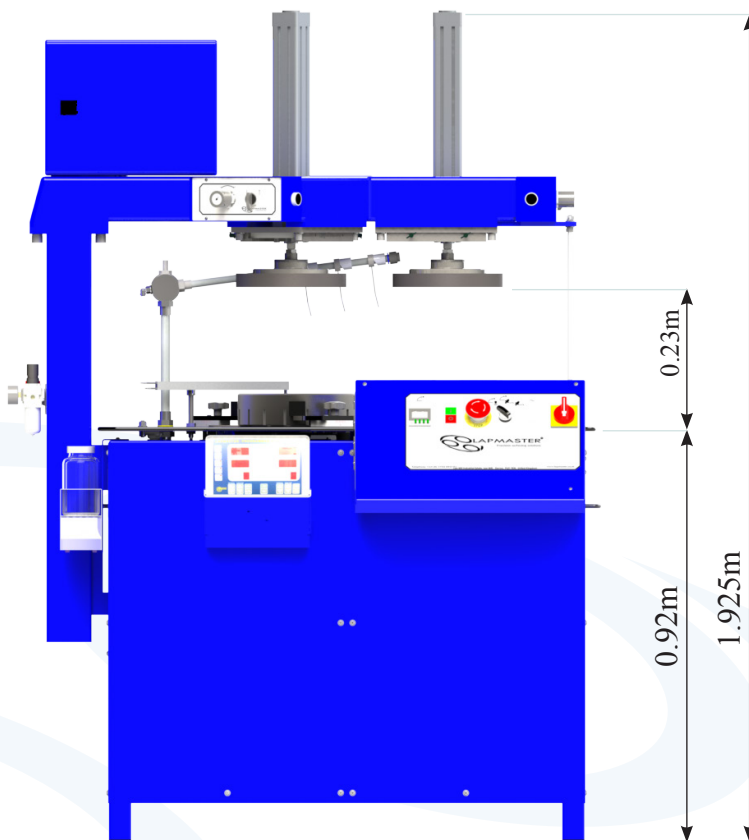
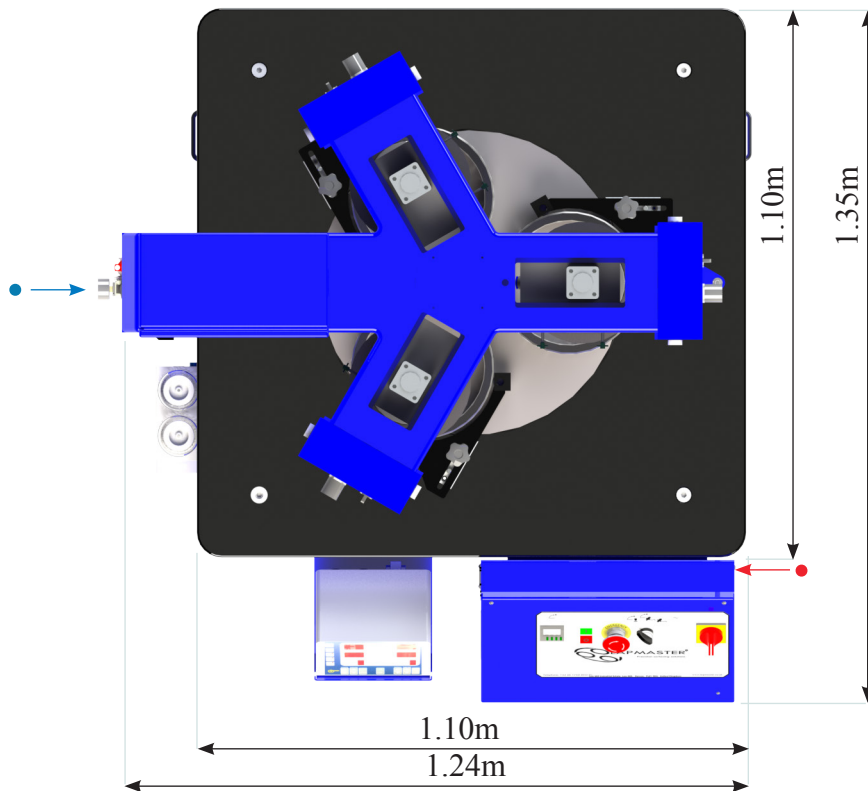

OPTIONAL TOOLING

- Flatness gauge.
- Solid stainless steel backing plates.
- Composite faced polishing plates.
- Cast iron lap plate.
- Polishing pads.

OPTIONAL FEATURES

- Four ring model.
- Open face version.
- Electronic variable speed drive.
- Electronic soft start to main drive.
- Water cooled lap plate.
- Non-standard voltages.
- Stainless steel wetted parts.
- Peristaltic pump.
- Corporate colours.
- Fixed guarding.

APPROXIMATE WEIGHT

- 700 kg.

SERVICES

- **Electrical:** 230/380V, 3 Phase, 50Hz.
230V, 1 Phase, 50/60Hz.
- **Air:** 400 kPa / 4 bar minimum.
- **Water:** 100 kPa / 1 bar minimum.
(if applicable).

Lapmaster Wolters Ltd

International Lapping, Grinding and Polishing Machine Systems

Lee Mill Industrial Estate, Ivybridge, Devon, PL21 9EN UK

T: + 44 (0)1752 893191 F: + 44 (0)1752 896355 E: sales@lapmaster-wolters.co.uk

www.lapmaster-wolters.co.uk

